



www.rvmoveis.com.br

 @rvmoveismirassol

 @rvmoveismirassol

### ESQUEMA DE MONTAGEM

**\*ESTE MANUAL SERVE PARA A  
MESA ÁGATA 1,20 RETA**

As Opções dos Pés Redondos e Oblongos  
São Vendidos Separadamente.

**OBSERVAÇÃO:  
O VIDRO JÁ VAI FIXADO NO TAMPO**

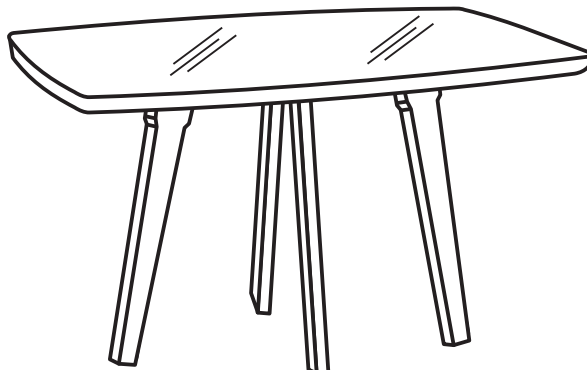
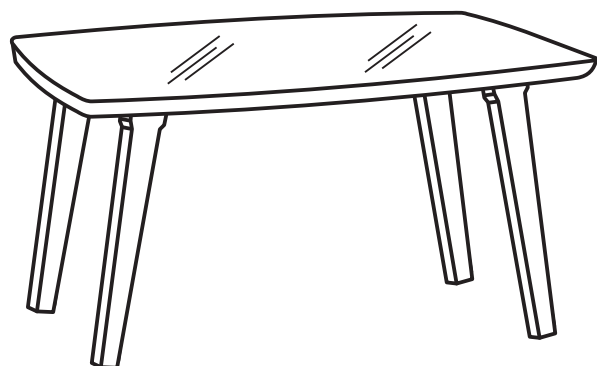
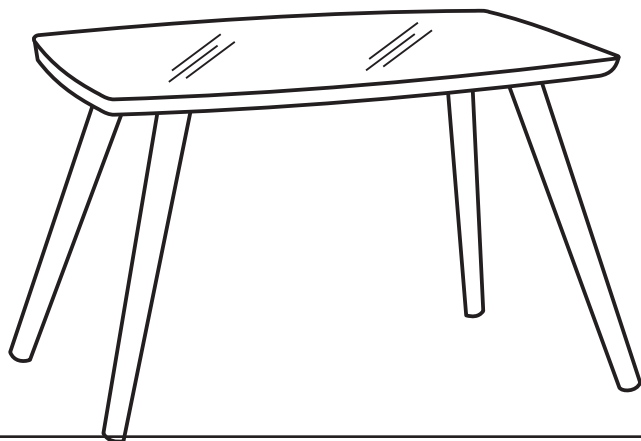





N° PEÇA	DESCRIÇÃO	QTD.	COMP.	LARG.	ESPESS.
01	TAMPO	01			
02	PÉ	04			

### MESA 1,20x0,90 BARRIL/PALITO

BLACK MS1802	BRANCO CLEAN MS1811	WHITE MS1803
-----------------	---------------------------	-----------------

### MESA 1,70x0,90 BARRIL/PALITO

BLACK MS1802	WHITE MS1805
-----------------	-----------------







COD.	DESCRIÇÃO	QTD.	DESCRIÇÃO
	PARAFUSO 4,5x60	16	
	PARAFUSO 4,5x25 CHATO	28	
	SUPORTE PÉ	04	
	PÉ REDONDO	04	

### MESA 1,20x0,90 BARRIL/OBLONGO

BLACK MS4701	BRANCO CLEAN MS4703	WHITE MS4702
-----------------	---------------------------	-----------------

### MESA 1,70x0,90 BARRIL/OBLONGO

BLACK MS4801	WHITE MS4802
-----------------	-----------------

COD.	DESCRIÇÃO	QTD.	DESCRIÇÃO
	PARAFUSO 4,5x60	12	
	PARAFUSO 4,5x25 CHATO	24	
	SUPORTE PÉ	04	
	PÉ OBLONGO	04	
	SAPATA ANTIUMIDADE PRETA	04	
	PARAFUSO 3,5X14 CHATO	04	

1°

Detalhe da Fixação do Pé no Suporte.

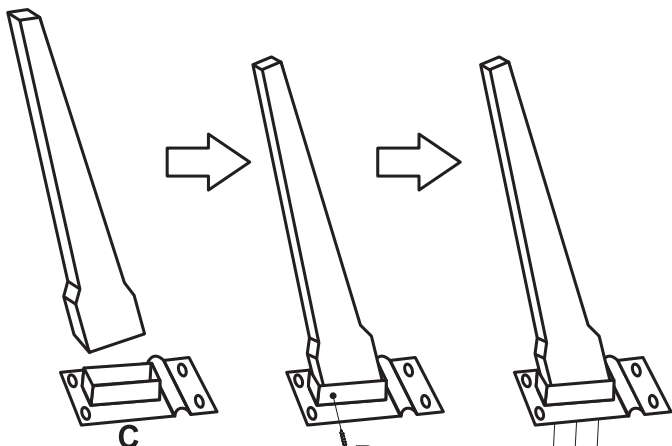

OBS.: TRAVAR O PÉ NO SUPORTE COM 2 PARAFUSO 4,5x25(B)

OBS.: FIXAR O PÉ OBLONGO NO SUPORTE POR BAIXO, UTILIZANDO 03 PARAFUSOS 4,5x60(A)



OBS.: FIXAR O PÉ REDONDO NO SUPORTE POR BAIXO, UTILIZANDO 04 PARAFUSOS 4,5x60(A)

2°

SR. MONTADOR, ATENÇÃO NA ANGULAÇÃO DOS PÉS.

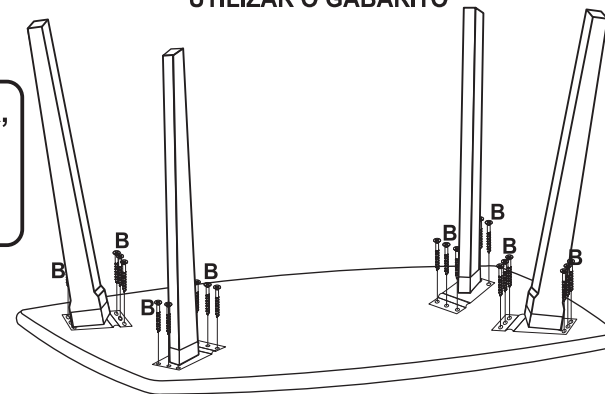

ATENÇÃO:  
AS MESAS DE 1,10 E DE 1,20 POSSUEM 02 OPÇÕES DE FIXAÇÃO DOS PÉS, UTILIZAR O GABARITO

ATENÇÃO Sr. MONTADOR, UTILIZAR O PAPELÃO PARA FERRAR O CHÃO PARA PROTEGER O M VEL NA HORA DA MONTAGEM.

OPÇÃO DE FIXAÇÃO DOS PÉS PARA MESA 1,10 E 1,20

3°

OPÇÃO DE FIXAÇÃO DOS PÉS PARA MESA 1,10 / 1,20 / 1,70.



OPÇÃO DE FIXAÇÃO DOS PÉS PARA MESA 1,10 E 1,20

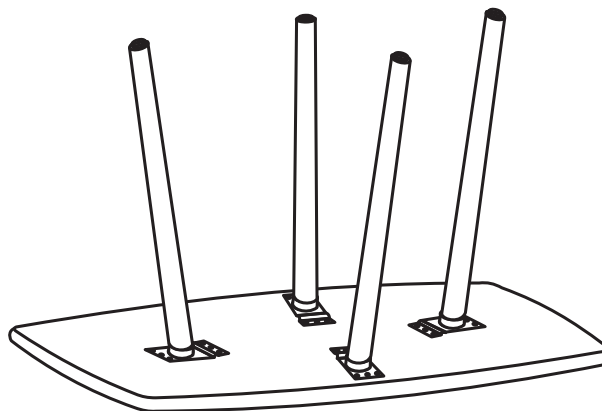

4°

